



US007278273B1

(12) **United States Patent**  
**Whitted et al.**

(10) **Patent No.:** **US 7,278,273 B1**

(45) **Date of Patent:** **Oct. 9, 2007**

(54) **MODULAR DATA CENTER**

6,786,056 B2 \* 9/2004 Bash et al. .... 62/199  
6,859,366 B2 \* 2/2005 Fink ..... 361/690

(75) Inventors: **William H. Whitted**, Palo Alto, CA  
(US); **Gerald Aigner**, Zurich (CH)

**OTHER PUBLICATIONS**

(73) Assignee: **Google Inc.**, Mountain View, CA (US)

Baumgart et al., "Petabyte Box for Internet Archive", Nov. 8, 2003.  
"Designing & building efficient data centers", PlanetTen, Jul. 2003.

(\* ) Notice: Subject to any disclaimer, the term of this  
patent is extended or adjusted under 35  
U.S.C. 154(b) by 25 days.

\* cited by examiner

*Primary Examiner*—Chen Wen Jiang  
(74) *Attorney, Agent, or Firm*—Jung-hua Kuo

(21) Appl. No.: **10/750,330**

(57) **ABSTRACT**

(22) Filed: **Dec. 30, 2003**

(51) **Int. Cl.**  
*F25D 23/12* (2006.01)  
*F25D 17/06* (2006.01)  
*H05K 7/20* (2006.01)

Modular data centers with modular components suitable for use with rack or shelf mount computing systems, for example, are disclosed. The modular center generally includes a modular computing module including an intermodal shipping container and computing systems mounted within the container and configured to be shipped and operated within the container and a temperature control system for maintaining the air temperature surrounding the computing systems. The intermodal shipping container may be configured in accordance to International Organization for Standardization (ISO) container manufacturing standards or otherwise configured with respect to height, length, width, weight, and/or lifting points of the container for transport via an intermodal transport infrastructure. The modular design enables the modules to be cost effectively built at a factory and easily transported to and deployed at a data center site.

(52) **U.S. Cl.** ..... **62/259.2**; 62/414; 62/418;  
361/690; 361/695

(58) **Field of Classification Search** ..... 62/259.2,  
62/414, 418; 165/80.3, 121, 104.33; 360/690,  
360/691, 695, 696, 698, 694

See application file for complete search history.

(56) **References Cited**

**U.S. PATENT DOCUMENTS**

3,777,506 A \* 12/1973 Hergatt et al. .... 62/237  
5,544,012 A \* 8/1996 Koike ..... 361/695  
6,412,292 B2 \* 7/2002 Spinazzola et al. .... 62/89  
6,494,050 B2 \* 12/2002 Spinazzola et al. .... 62/89

**41 Claims, 4 Drawing Sheets**

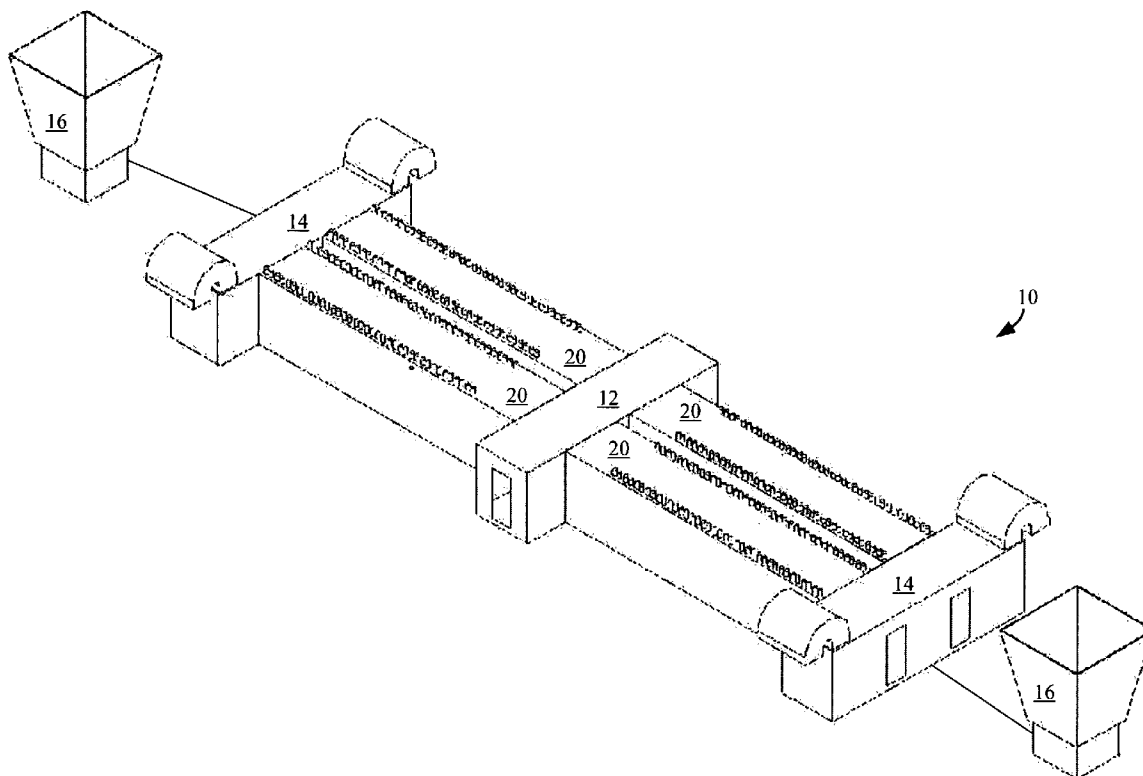

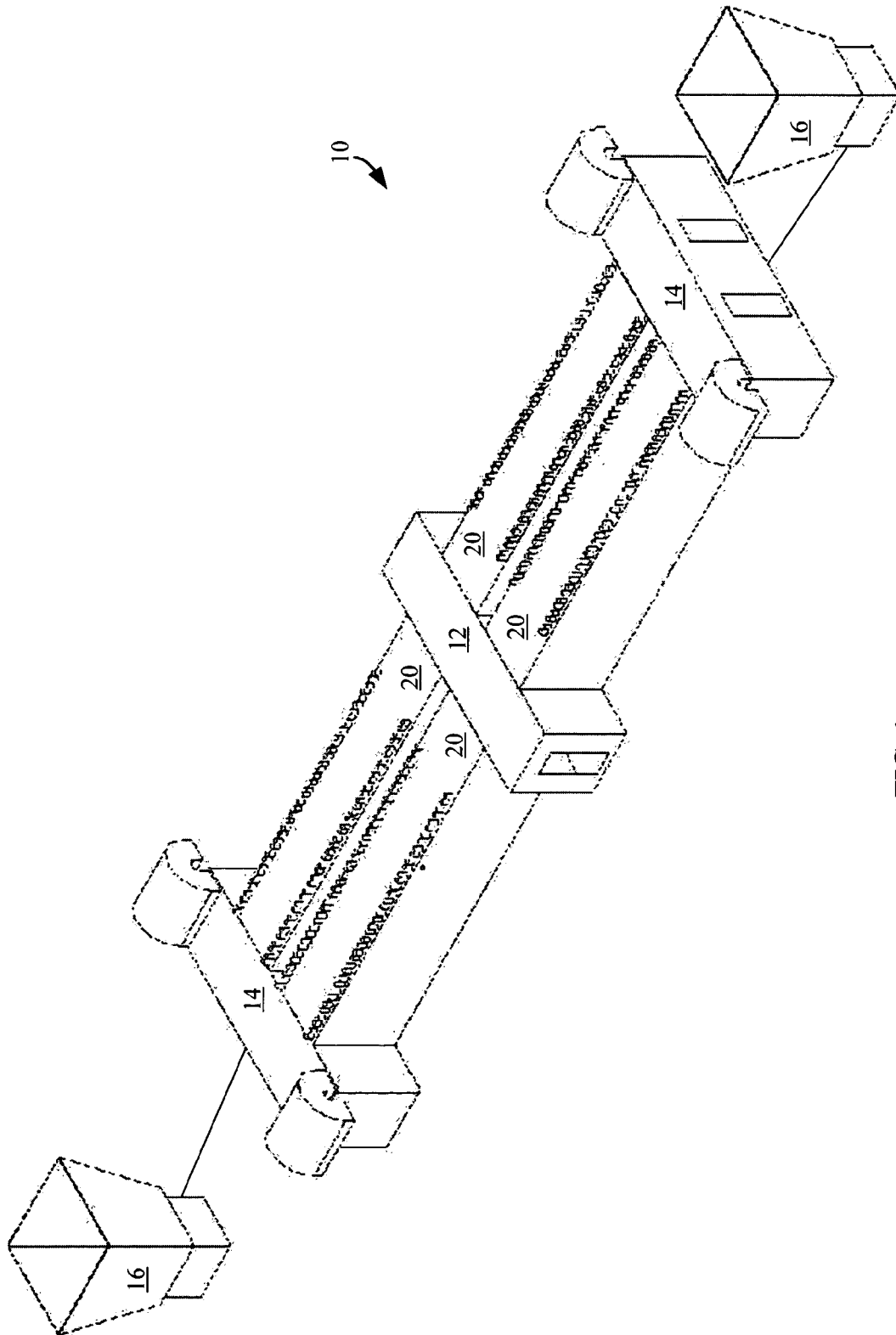

FIG. 1

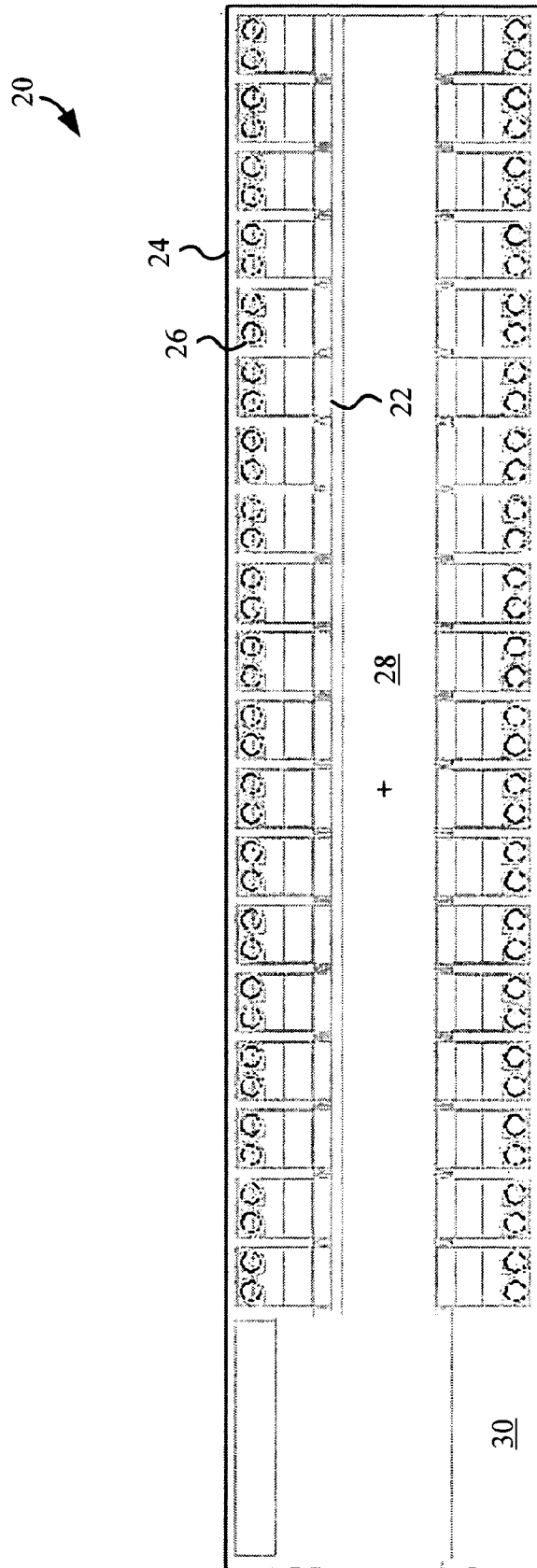

FIG. 2

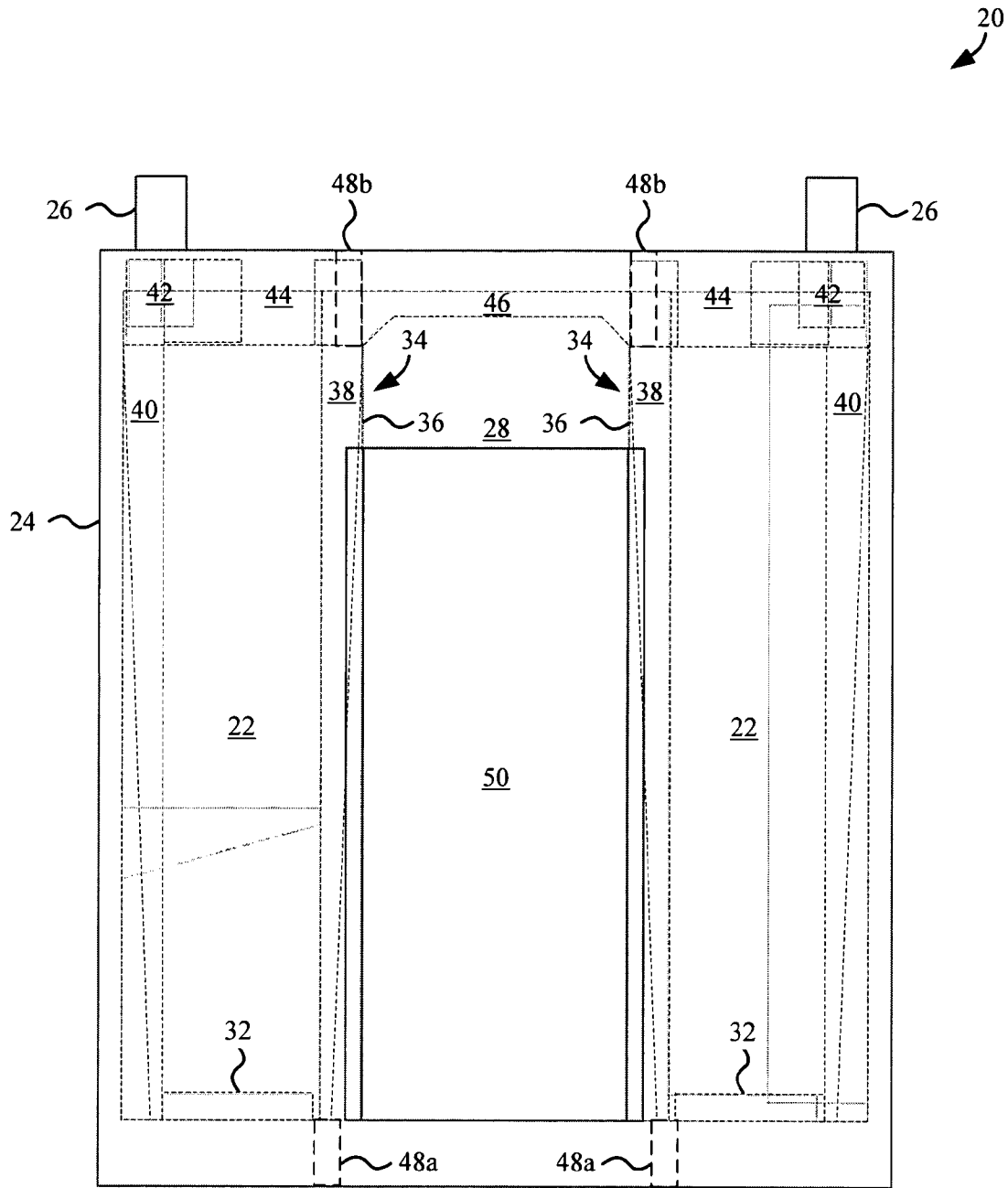

FIG. 3

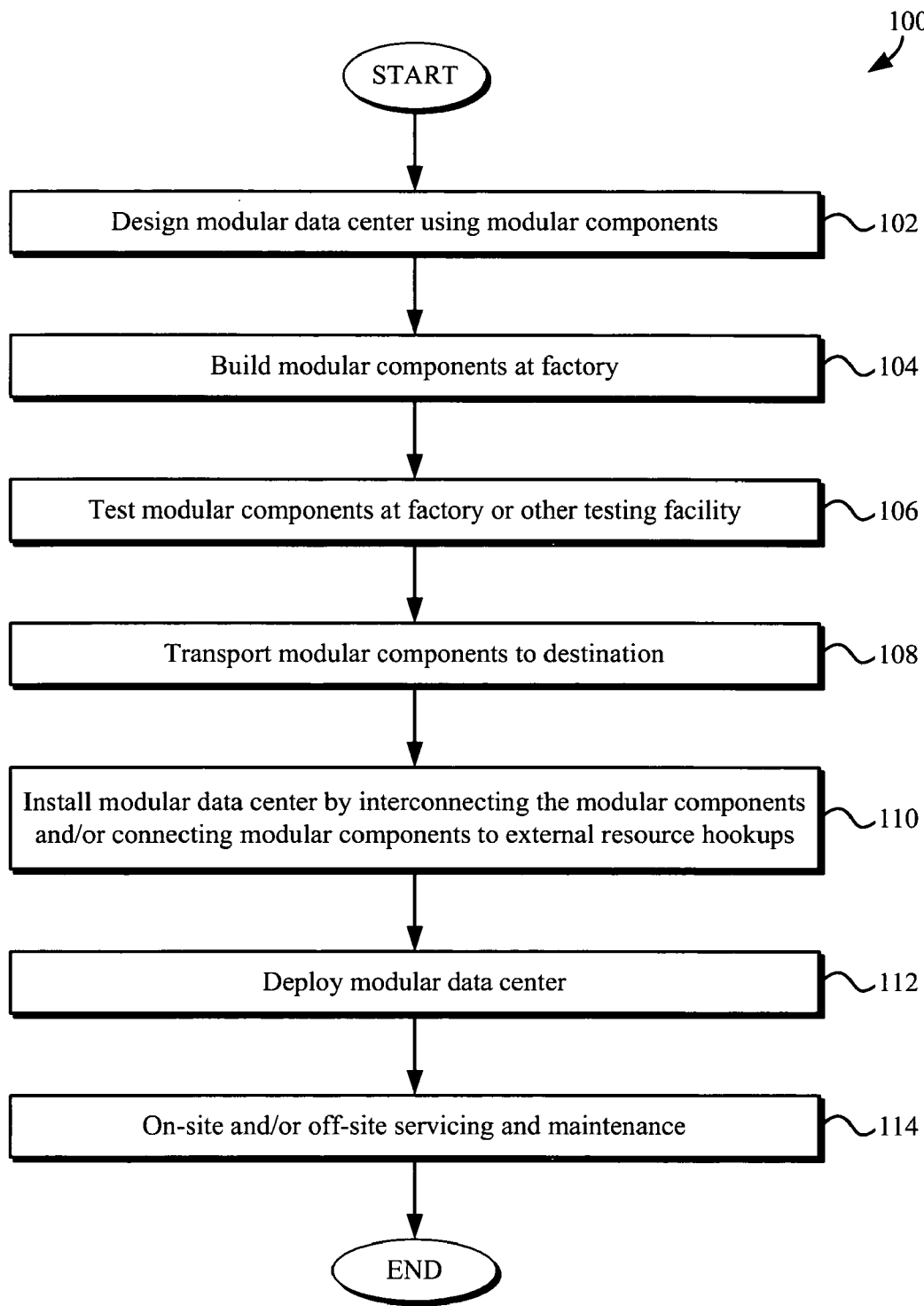

FIG. 4

**MODULAR DATA CENTER**

## BACKGROUND OF THE INVENTION

## 1. Field of the Invention

The present invention relates generally to computing data centers. More specifically, modular data centers with modular components suitable for use with rack or shelf mount computing systems, for example, are disclosed.

## 2. Description of Related Art

Many of today's more complex computing systems such as computer server systems are often rack-mounted systems in which a number of removable electronics modules, such as electronics trays, are positioned and stacked relative to each other in a shelf-like manner within a frame or rack. Rack-mounted systems allow the arrangement of several of the electronics modules in a vertical orientation for efficient use of space. Each electronics module can be slid into and out of the rack-mounting system.

Each electronics module may correspond to a different server or each electronics module may hold one or more components of a server. Examples of electronics modules include modules for processing, storage such as random access memory (RAM), network interfaces and controllers, disk drives such as floppy disk drives, hard drives, compact disk (CD) drives, and digital video disk (DVD) drives, parallel and serial ports, small computer systems interface (SCSI) bus controllers, video controllers, power supplies, and so forth.

A server farm in today's computing environment may be housed in a data center such as a colocation and may include hundreds of racks that hold various types of computer-related modules. When the server racks are installed in the colocation site, a number of interrelated processes are planned out and executed, generally in a relatively short period of time. Examples of such processes include physical layout of the server racks, configuration and wiring of electrical power connections to the server racks, layout of flow-control elements in the cooling system of the data center space, and/or the installation of Internet connectivity wiring and networking systems. Typically, these processes are completed on-site at the colocation site by costly skilled tradesmen. In addition, because installation at each site is customized to take into account site-specific constraints, i.e., site to site variations in data centers, installation difficulties arise and economies of scale cannot be fully exploited on installations. Furthermore, because of the site-specific constraints, the processes are different for each site such that each site provides new opportunities for costly design and/or installation errors. Currently, the time from determining the need to starting to serve production traffic can be approximately 6 to 9 months.

To further increase the costs, many colocations are relatively expensive to use or lease and typically are not setup for convenient operations or for easy deployment of large scale server racks, for example. In large scale deployments, many potential opportunities to maximize power, cooling, ventilation, lighting, and space utilization, are not easily exploited at colocation sites. Colocations also often have issues associated with power, cooling, and/or personnel. Moreover, the available colocation sites may be limited.

As an example, a large scale deployment of a server farm such as a mega data center, may involve 300,000 computers, with a service life of approximately four years per machine. In such a large scale server farm, an average of over 1,400 computers per week are de-racked and racked just to keep pace with end-of-service machines. At a rack density of 40

trays per rack and 1 computer per tray, approximately 36 racks are replaced each week.

## SUMMARY OF THE INVENTION

Modular data centers with modular components suitable for use with rack or shelf mount computing systems, for example, are disclosed. It should be appreciated that the present invention can be implemented in numerous ways, including as a process, an apparatus, a system, a device, or a method. Several inventive embodiments of the present invention are described below.

According to one embodiment, a modular data center generally includes a modular computing module including an intermodal shipping container and computing systems mounted within the container and configured to be shipped and operated within the container and a temperature control system for maintaining the air temperature surrounding the computing systems. The intermodal shipping container may be configured in accordance to International Organization for Standardization (ISO) container manufacturing standards or otherwise configured with respect to height, length, width, weight, and/or lifting points of the container for transport via an intermodal transport infrastructure. The modular design enables the modules to be factory built and easily transported to and deployed at a data center site.

For example, the intermodal shipping container may have a height of approximately 8 feet 6 inches or 9 feet 6 inches and a width of approximately 8 feet. The computing systems may be arranged for human access within the intermodal shipping container. The modular data center may also include an interconnecting module to interconnect modular computing modules, a power generating for generating power for the modular computing module, and/or a cooling module for providing cooling for the temperature control system, each module being relatively self-contained within another intermodal shipping container. The modular components of the modular data center need not employ intermodal shipping containers of the same size. The cooling module may contain, for example, a compressor, a condensing coil, heat exchanger, pumps, controls, and/or motors for a temperature control system. The modular data center may additionally include an evaporative, compressed fluid, or other suitable cooling system in communication with the modular computing module.

The computing systems may be mounted within rack and/or shelf mounting structures and each mounting structure may be enclosed in an enclosure with an access door, each enclosure being associated with an independent temperature control subsystem. Each temperature control subsystem may include a blower and an evaporator coil, the blower including a blower motor and blower blades mounted external and internal to the intermodal shipping container, respectively. The enclosure may also define a delivery plenum and a return plenum in thermal communication with the corresponding temperature control subsystem and with the computing systems contained within the corresponding enclosure. The modular computing module may also include a gas-side economizer in thermal communication with the corresponding temperature control subsystem.

According to another embodiment, a data center may generally include a modular computing module including an intermodal shipping container configured for transport via an intermodal transport infrastructure with respect to height, length, width, weight, and/or lifting points of the container, computing systems mounted within the container and con-

figured to be shipped and operated within the container, a power distribution unit configured to distribute power from a power source to the computing systems, and a network interface configured to interface between an Internet access connection and the computing systems, and a temperature control system for maintaining a predetermined air temperature surrounding the computing systems.

According to yet another embodiment, a method for deploying a data center generally includes building a modular computing module including an intermodal shipping container configured in accordance to ISO container manufacturing standards and/or configured for transport via an intermodal transport infrastructure and computing systems mounted within the intermodal container and configured to be shipped and operated within the intermodal container, transporting the modular computing module to a data center site via an intermodal transport infrastructure, and connecting a resource connection to the modular computing module.

These and other features and advantages of the present invention will be presented in more detail in the following detailed description and the accompanying figures which illustrate by way of example the principles of the invention.

#### BRIEF DESCRIPTION OF THE DRAWINGS

The present invention will be readily understood by the following detailed description in conjunction with the accompanying drawings, wherein like reference numerals designate like structural elements.

FIG. 1 is a perspective view of an illustrative implementation of a modular data center suitable for use with rack and/or shelf mount computing systems.

FIG. 2 is a top view of an illustrative implementation of a computing module for use in a modular data center.

FIG. 3 is a side view of an illustrative implementation of a computing module for use in a modular data center.

FIG. 4 is a flowchart of an illustrative process for constructing and deploying a modular data center.

#### DESCRIPTION OF SPECIFIC EMBODIMENTS

Modular data centers with modular components suitable for use with rack or shelf mount computing systems, for example, are disclosed. The following description is presented to enable any person skilled in the art to make and use the invention. Descriptions of specific embodiments and applications are provided only as examples and various modifications will be readily apparent to those skilled in the art. The general principles defined herein may be applied to other embodiments and applications without departing from the spirit and scope of the invention. Thus, the present invention is to be accorded the widest scope encompassing numerous alternatives, modifications and equivalents consistent with the principles and features disclosed herein. For purpose of clarity, details relating to technical material that is known in the technical fields related to the invention have not been described in detail so as not to unnecessarily obscure the present invention.

FIG. 1 is a perspective view of an illustrative implementation of a modular data center 10 suitable for use with rack and/or shelf mount computing systems. The modular data center 10 includes at least one computing module 20 each with multiple computing units contained in an intermodal shipping, e.g., dry van, container. In the example shown in FIG. 1, the modular data center 10 includes four computing modules 20 as well as an office module 12 interconnecting the four computing modules 20, optional power and cooling

modules 14, and optional cooling towers 16 housing, e.g., condensers. The power and cooling module 14 may contain power generation equipment and most of the cooling equipment (e.g., compressor(s), heat exchangers, circulation pumps, controls, etc.). At sites with a nearby natural cooling mechanism, e.g., river, lake, or ocean, the natural cooling mechanism may be employed to cool the condensing of the cooling fluids. At certain locations that are very dry, e.g., Phoenix, Ariz., water may be sprayed onto the coils carrying the cooling fluids in the cooling tower 16 as air is blown past the coils. If the available air is sufficiently warm and dry, such a system may provide sufficient cooling.

Each of the computing modules 20, office module 12, and power and cooling modules 14 may include an intermodal shipping container such that each may be assembled in a factory and then both shipped and deployed in the intermodal shipping container. The intermodal shipping containers may be readily purchased, e.g., off the shelf, or may be custom or specially manufactured to standards for the intermodal shipping container industry with respect to, for example, size, maximum weight, lifting points, etc. Such use of standard modular shipping containers enables the data center components to easily fit into existing worldwide air, road (e.g., truck), rail, and/or vessel (e.g., ship and barge) container handling infrastructure that also includes standardized container handling hardware. In addition, the standard intermodal shipping containers are relatively inexpensive and robust while large enough to contain a good amount of computing and/or self-contained power conversion, cooling, and connectivity interfaces, etc. As the shipping container and its contents are shipped in the container itself and deployed with minimum, if any, additional on-site configuration, the various components within the container can be secured, e.g., with appropriate mounting apparatus, within the container, e.g., to the walls, floor, ceiling and/or internal structure of the container and/or to each other.

Intermodal shipping containers, as used herein, refer to those that conform to International Standardization Organization (ISO) container manufacturing standards. In general, the intermodal shipping containers can be, for example, general purpose or dry, insulated, flat rack or platform, open top, refrigerated, or tank. General purpose containers, also referred to as cube containers, are enclosed, box-type containers used for general-purpose transportation. Cargo is typically loaded from one or both ends of the container. Insulated or thermal containers, with insulated walls but no refrigeration unit, are often used to transport chilled and frozen goods as well as temperature sensitive materials and products. Intermodal shipping containers also come in many other configurations, e.g., with one or more end and/or side doors and/or specially reinforced floors and/or frames for extra heavy loading. Generally, common container lengths used in international commerce include 20', 28', 40' and 48' as well as other sizes such as 10', 24', 44', 45', 46', 53', and 56'. Typical container height is 8'6" or 9'6" for high cube or extended height containers. The standard width for containers is 8'. Various other combinations of lengths, widths, and/or heights may also be employed. The containers may be made of, for example, steel, aluminum, or the like. Typically, because of weight constraints such as maximum load limits on highways, high density or heavy goods may be loaded in shorter containers. For example, in one implementation a 40' container with a full complement of computers, can weigh approximately 20,000 pounds as compared to a typical container rating of approximately 67,000 pounds. Intermodal shipping containers generally have fittings on the top and bottom which facilitate in their handling

and that enable them to be stacked in terminals, on ships, and/or in operation. The fittings primarily include oval-shaped holes at the lift points. For transport, storage or operation, containers may be stacked and connected to each other with interbox connectors (IBCs), i.e., pieces of hardware that fit into the oval holes of the containers above and below and are turned to lock the two containers together.

It is to be appreciated that while the standard intermodal shipping containers enjoy the convenience and cost savings associated with the existing container handling infrastructure, many other form factors may be employed such as a mechanical structures capable of supporting large numbers of computers, provide sufficient level of environmental protection, and facilitate the connection of power and the Internet to the supported computers.

By shipping and also deploying the data center modules **12, 14, 16, 20** in the intermodal shipping containers, the components may be factory built and/or tested. Note that the cooling towers **16** may be shipped in the intermodal shipping containers and site-configured as needed. Building and testing the data center components in the intermodal shipping containers may be cost effectively achieved in a controlled environment of a centralized factory or other build facilities. Such factory building and testing reduces the cost and time associated with conventional installation at a collocation site with site-specific requirements and constraints that would also otherwise involve costly skilled tradesmen, particularly to complete the build-out of power, network wiring, and/or cooling systems. The data center components may also enjoy the cost savings associated with mass assembly. Fully building and testing the data center components on the factory assembly floor also helps to reduce costly design and/or installation errors and helps to exploit economies of scale.

System level testing on the modular data components may be performed by expert testing staff before the modular data components are shipped from the factory. Many other elements that are usually beyond the data center customer's control can be easily monitored. The building of the modular data components on the factory assembly floor would thus result in a better and also more consistent end product.

The use of modular data components allowing for design standardization and a greater amount of control over the assembly and testing processes also provides opportunities to apply advanced cooling and power management monitoring and control systems. The design costs of such cooling and power management monitoring and control systems may be amortized over a large number of modular data components versus the conventional approach that takes into account site-specific constraints and even separate areas within a site.

The use of data center modules may also substantially reduce the time to commission a cluster, e.g., 1 to 2 months. Modular components are particularly suited for deploying large clusters of individual computers, e.g., over 1,000 computers, although smaller clusters may also enjoy the benefits of utilizing one or more modular components of a modular data center.

The modular data center **10** may be located where real estate is inexpensive such as in former industrial sites, in a yard with a stable and graded surface, at sites near power dams and/or railways with, for example, access to resources such as electricity, natural gas (e.g., for power generation), water (e.g., for cooling), and/or Internet access (e.g., wired including optical connections and/or wireless such as satellite). After the data center modules **12, 14, 16, 20** reach the data center site, the components may then be easily and

efficiently connected to electrical, natural gas, water, Internet access, and/or other connections and/or to each other to form the modular data center **10**. The resource hookups may be industrial standard quick connects such that the modular data center and/or each modular component can be quickly and easily installed and removed and/or the hookups may be automated. The data center modules **12, 14, 16, 20** may also be stacked, e.g., up to 8 high, to conserve real estate. Thus the use of modular data centers **10** eliminates many of the logistic difficulties inherent in building data centers at unique and distant sites such as at collocation centers.

In one embodiment, each modular component can be a largely self-contained system. Each modular component may be assembled with the electrical distribution and/or network interconnectivity required by the computing units of the modular components. In some embodiments, the site installation involves only unloading of the modular component(s) from the delivery vehicles and connecting electricity, gas, water, Internet, and/or various other connections. For example, modular component(s) may include a power distribution unit (PDU) for distributing power from a central power source to the computing units and/or a network interface to interface between an Internet access connection and the computing units. Power may be supplied by another modular component containing a co-generating station that may, for example, uses natural gas to supply the electrical and cooling power for the other modular components. Thus the modular data center would contain a built-in system of power generation and distribution.

As is known, a co-generating station is a power generating scheme that uses waste heat from a primary generator driving device for some other purpose. For example, a natural gas may be utilized to fuel a gas turbine to generate electricity. The exhaust from the gas turbine is very hot (e.g., approximately 700° C.) such that water injected into the exhaust flashes into steam and can be run through a steam turbine to power a second generator to generate additional electricity. The exhaust of the steam turbine can be reasonably warm (e.g., approximately 90° C.) and can be used to power a direct absorption refrigeration system. As is evident, the triple use of the various forms of energy can greatly improve efficiency.

By the nature of the modular components, the modular components may be sited within an existing building structure, outdoors exposed directly to the elements, under an overhead protective car-port style roof structure, and/or various other combinations. As shown in FIG. 1, multiple modular component may optionally be connected to each other via a system of additional modules acting as interconnecting hallways, offices, and/or convenience facilities for the use of service employees.

Once deployed, each modular component can be serviced on site with human access. Alternatively or additionally, an entire modular component may be conveniently and easily disconnected and transported to a service center where the modular component can be opened and the contents replaced en masse for upgrades, recycling, etc. It is noted that the modular data center is well suited to be a computing center particularly for large scale deployments, e.g., large scale deployments of generic applications and/or specialized applications.

FIG. 2 is a top view of an illustrative implementation of a computing module **20** for use in a modular data center. As shown, the computing module **20** may include a number of racks or shelves **22** housed in an intermodal shipping container **24**. Each rack or shelf **22** contains several rack and/or shelf mounted computing systems. Various other

types of mounting mechanisms for the computing systems may be additionally or alternatively employed. Each rack **22** may be an individual cabinet housed in the container **24**. Alternatively, the racks or shelves **22** may be in the form of open bays with shelf holders built into the structure of the container **24**. Specifically, each rack **22** may include posts that serve as structural components of the container **24** and that carry shelf holders for holding individual computing shelves.

Blower motors **26** may extend from the rack or shelf **22** to expel warm air. As shown, two blower motors **26** may be provided for each rack/shelf **22** depending upon available space, physical limitations, resource limitations, and/or provisions for redundancy. Locating the blower motors **26** outside of the container **24** helps to keep the heat generated by the blower motors **26** outside of the container **24** as well. Although the blower motors **26** are shown extending from the top of the container **24**, the blower motors **26** may also extend out from the sides of the container **24** or may be contained within the intermodal shipping container to facilitate transport, for example.

The racks or shelves **22** may be arranged so as to provide a walkway **28** between two rows of the racks/shelves **22** for service access and/or to facilitate temperature and/or humidity control. In addition, a workbench **30** can optionally be provided at one end of the container **24**.

FIG. **3** is a side view of an illustrative implementation of a computing module **20** for use in a modular data center. As shown, the computing module **20** may provide a door **50** at one end to provide access for service personnel on-site at the data center location and/or for personnel access at the factory, for example. Doors may be provided at either or both ends and/or at sides, for example. Alternatively or additionally, openings without doors may similarly be provided such as openings that interconnect adjoining intermodal shipping containers. Each rack or shelf **22** includes multiple computing units **32**, one of which is shown for each rack/shelf **22** on either side of the computing module **20**. As is common, the computing units **32** may be vertically racked or shelved one over the next approximately the entire internal height of the rack/shelf **22**.

Preferably, the walls of the container **24** are insulated to facilitate in economically maintaining internal temperatures. Each computing module **20** may implement a built-in refrigerated cooling system to remove waste heat generated by the computing units **32**. For example, each rack/shelf **22** may include an enclosure **34** enclosing the computing units **32** contained in the rack/shelf **22** and having a door **36** that can open into the walkway **28** for access by personnel. Each rack/shelf **22** being in its own enclosed environment allows finer granularity of temperature and/or humidity control via a temperature control subsystem corresponding to the rack/shelf **22**. The door **36** and the fronts of the computing units **32** may form a front plenum **38**. A rear plenum **40** may also be formed between the back of the enclosure **34** and the backs of the computing units **32**. The front and rear plenums **38**, **40** communicate via spaces between the computing units **32** and facilitate air circulation for purposes of cooling the computing units **32** of the rack/shelf **22**, for example.

In particular, the cooling subsystem for each computing unit **32** may generally include an evaporator coil **44** and a blower having the blower motors **26** and blower blades **42** to push warm air over the evaporator coil **44** to cool the warm air. The evaporator coil **44** may be in fluid communication with the condenser output and a compressor suction line, for example. The blower may push cool air into the front plenum **38** (e.g., cold air delivery plenum), over the

computing units **32** to cool the computing units **32** and pull warm air through the rear plenum **40** (e.g., warm air return plenum). Alternatively, the blower may push cool air into the rear plenum **40**, over the computing units **32** to cool the computing units **32** and pull warm air through the front plenum **38**. In one embodiment, the front and rear plenums **38**, **40** may be tapered to have a larger cross sectional area near the top of the enclosure **34** than at the bottom of the enclosure **34** in order to compensate for an air pressure gradient that may otherwise be present from the top to the bottom of the enclosure **34**. The tapering thus facilitates the cooling system in drawing approximately the same volume of air flow over each computing unit **32** for more even cooling. Other mechanisms may also be employed to facilitate achieving uniform air pressure and thus equalization of the volume of air flow.

Other systems of internal or external water chillers, articulated ventilation panels, and/or other cooling devices, separately or in combination, may also be employed. For example, the computing module **20** may further include an inlet and outlet vents **48a**, **48b**, respectively, e.g., a gas-side economizer, preferably with dampers that operate in unison. As shown, the economizer inlet vents **48a** may be located at the bottom of the module, e.g., to access the cooler air while the economizer outlet vents **48b** may be located at or near the top of the module, e.g., to allow warm air to escape. Such a configuration of the economizer inlet and outlet vents **48a**, **48b** may facilitate in moving warm air out of the module while drawing cooler air in, similar to a chimney.

The blowers may be utilized to cooperate with the inlet and outlet vents **48a**, **48b** to move outside air through each rack/shelf **22** of the computing module **20**. In addition, water vapor may also be added to outside air, for example, if the ambient air temperature is very cold or if the ambient air is otherwise very dry, in order to maintain a desired relative humidity inside the module. The inlet and outlet vents may utilize outside air when the outside air is cooler, e.g., 10° F. or more cooler than the desired internal temperature to satisfy at least some of the cooling needs of the computing module **20**. For example, the inlet and outlet vents may be in thermal communication with a crawlspace under the container **24** if, for example, the container **24** is secured to a concrete foundation forming the crawlspace. As another example, the inlet and outlet vents may extend through side walls and/or ceiling of the container **24**.

The computing module **20** may further provide a wire race **46** for housing, for example, Cat 5 cables, electrical and/or various other cables. The wire race **46** may run approximately the length of the container **24** above the walkway **28**. However, various other configurations may also be employed. The computing module **20** may also include a power distribution unit (PDU) to distribute power among the racks/shelves **22**.

The computing module **20** may also provide motion sensors (not shown) to detect motion along the walkway **28**, e.g., to sense the presence of a service technician, for example. The motion sensors may be in communication with light switches and/or fresh air vents, for example, such that when a service technician enters the computing module **20**, the motion sensors automatically causes the lights to turn on and the fresh air vents to open to provide light and fresh air in the computing module **20**. In order to conserve energy, the motion sensors may automatically turn off the lights and close the fresh air vents after absence of detecting motion for a predetermined period of time, e.g., 5 minutes.

It is noted that in FIGS. 1-3, components of the modular data center 10 such as the computing module 20 in FIGS. 2 and 3 may not be drawn to scale.

FIG. 4 is a flowchart of an illustrative process 100 for constructing and deploying a modular data center containing one or more modular components. At block 102, a modular data center is designed using modular components. The modular data center may include one or more modular components and the modular components may include, for example, computing modules, office modules, power and/or cooling modules, and/or cooling towers. The computing module may also be a largely self-contained system.

The modular components of the modular data center are built at a factory or other centralized build facilities at block 104. The modular components can be tested either at the same factory or at a separate testing facility at block 106. The modular components are then transported to the destination at block 108. Because most if not all of the modular components are self-contained within an intermodal shipping container of the same or various sizes, transporting the modular components can be easily achieved utilizing the existing worldwide road, rail, and/or vessel container handling infrastructure.

At block 110, the modular components are interconnected and/or connected to external resources such as electricity, natural gas, water, and/or Internet connections to form the modular data center. At block 112, the modular data center is deployed and placed into operation. At block 114, servicing and/or maintenance of the modular components may be performed on-site and/or off-site. For off-site servicing and/or maintenance, the respective modular component can be disconnected from other modular component(s) and/or various resource connections and transported to a servicing facility, e.g., the build factory or facility or a separate maintenance facility, and then returned to the original. Alternatively, a new replacement modular component can be brought to the site and the modular component being replaced can be disconnected and transported to a servicing facility, e.g., the build facility, and optionally placed back into service at the same or a different site. In particular, as each modular component reaches the end of its service life, the modular component may be disconnected from the remainder of the modular data center and removed from the site and a replacement modular component may be installed as a replacement. Similarly, as each rack/shelf and/or computing unit within the computing module reaches the end of its service life, that rack/shelf and/or computing unit may be disconnected from the remainder of the computing module and removed from the data center site and a replacement rack/shelf and/or computing unit may be installed as a replacement. Such a modular-method of servicing the modular data center also takes advantage of the use of modular components and the use of intermodal shipping containers.

Furthermore, the modular data center facilitates rapid and easy relocation to another site depending on changing economic factors, for example. The modular data center thus helps to make the moving of a data center more cost effective and thus more economically feasible. In one implementation, a modular system may reduce the cost of moving by approximately 60 to 80% to provide more viable options even within the nominal life of a module.

While the preferred embodiments of the present invention are described and illustrated herein, it will be appreciated that they are merely illustrative and that modifications can be made to these embodiments without departing from the spirit and scope of the invention. Thus, the invention is intended to be defined only in terms of the following claims.

What is claimed is:

1. A data center, comprising:
  - a shipping container configured for transport via a transport infrastructure; and
  - a plurality of computing systems mounted within the shipping container and configured to be shipped and operated within the shipping container; and
  - a cooling module of a temperature control system, the cooling module including another of said shipping container, the cooling module being separate from the computing systems of the at least one modular computing module.
2. The data center of claim 1, further comprising the temperature control system for maintaining a predetermined air temperature surrounding the computing systems.
3. The data center of claim 1, in which the computing systems are arranged to define an access way within the corresponding shipping container to provide human access to the computing systems.
4. The data center of claim 1, in which the computing systems are mounted within mounting structures, each mounting structure being one of a rack mounting structure and a shelf mounting structure.
5. The data center of claim 1, wherein the computing systems are mounted within mounting structures that are an integral structural component of the shipping container.
6. The data center of claim 1, in which the modular computing module further includes a plurality of computing system enclosures for enclosing and mounting the computing systems within the enclosures, the computing system enclosures being mounted within the shipping container, the data center further comprising a temperature control subsystem for each enclosure to provide independent temperature control within the enclosure.
7. The data center of claim 6, in which the temperature control subsystem of each enclosure includes a blower and an evaporator coil and in which the blower includes a blower motor and blower blades mounted external and internal to the shipping container, respectively.
8. The data center of claim 6, in which each computing system enclosure defines a first delivery plenum and a second return plenum in thermal communication with the corresponding temperature control subsystem, the first and second plenums being in thermal communication with the computing system contained within the corresponding enclosure.
9. The data center of claim 8, in which each computing system enclosure includes a gas-side economizer in thermal communication with the corresponding temperature control subsystem.
10. The data center of claim 6, in which each enclosure includes a door for access to the computing systems contained in the enclosure.
11. The data center of claim 1, in which the shipping container has a height selected from approximately 8 feet 6 inches and 9 feet 6 inches and a width of approximately 8 feet.
12. The data center of claim 1, wherein the transport infrastructure is an intermodal transport infrastructure and wherein each shipping container is configured for transport via the intermodal transport infrastructure.
13. The data center of claim 12, wherein each shipping container is configured in accordance with International Organization for Standardization (ISO) container manufacturing standards for transport via the intermodal transport infrastructure.

## 11

14. The data center of claim 1, further comprising at least one of:

an interconnecting module to interconnect a plurality of the modular computing modules, the interconnecting module including another of said intermodal shipping container;

a power generating module for generating power for the at least one modular computing module, the power generating module including another of said intermodal shipping container;

a power and cooling module integrated with the cooling module for generating power and for providing cooling for the temperature control system, power and cooling module including another of said intermodal shipping container; and

a cooling tower in communication with the modular computing module, the cooling tower comprising at least one of an evaporative cooler and a condenser portion of the temperature control system wherein the temperature control system is a direct expansion refrigeration system.

15. A method for deploying a data center, comprising: building at least one modular computing module at a first site, each including:

a shipping container configured for transport via a transport infrastructure; and

a plurality of computing systems mounted within the shipping container and configured to be shipped to and operated within the shipping container at a data center site; and

building a cooling module of a temperature control system, the cooling module including another of said shipping container configured to be in communication with the at least one modular computing module, the cooling module being separate from the computing systems of the at least one modular computing module; transporting the at least one modular computing module and the cooling module to the data center site different from the first site via the transport infrastructure; and connecting at least one resource connection to the at least one modular computing module.

16. The method of claim 15, in which at least one resource connection is selected from the group consisting of electricity, natural gas, water, and Internet access.

17. The method of claim 15, further including:

testing the computing systems of each modular computing module at the first site.

18. The method of claim 15, in which the transporting via the transport infrastructure includes transporting via at least one of air, road, rail, and vessel.

19. The method of claim 15, in which the computing systems are arranged to define an access way within the corresponding shipping container to provide human access to the computing systems.

20. The method of claim 15, in which the building includes mounting the computing systems within mounting structures, each computing system being one of rack mounted and shelf mounted within the corresponding mounting structure.

21. The method of claim 15, in which the building includes mounting the computing systems within mounting structures that are an integral structural component of the shipping container.

22. The method of claim 15, in which the building includes enclosing and mounting the plurality of computing

## 12

systems within computing system enclosures, the computing system enclosures being mounted within the shipping container.

23. The method of claim 22, in which the building includes installing a temperature control subsystem for each computing system enclosure configured to independently control the temperature within the corresponding enclosure.

24. The method of claim 23, in which the temperature control subsystem of each enclosure includes a blower and in which the building includes mounting a blower motor and blower blades of the blower external and internal to the shipping container, respectively.

25. The method of claim 23, in which each computing system enclosure defines a first delivery plenum and a second return plenum in thermal communication with the corresponding temperature control subsystem, the first and second plenums being in thermal communication with the computing system contained within the corresponding enclosure.

26. The method of claim 23, in which the building includes installing a gas-side economizer for each computing system enclosure, the gas-side economizer being in thermal communication with the corresponding temperature control subsystem of the computing system enclosure.

27. The method of claim 22, in which each enclosure includes a door for access to the computing systems contained in the enclosure.

28. The method of claim 15, in which the shipping container has a height selected from approximately 8 feet 6 inches and 9 feet 6 inches and a width of approximately 8 feet.

29. The method of claim 15, further including servicing the computing systems by one of:

performing on-site maintenance at the data center site; and

performing off-site maintenance by transporting the at least one modular computing module to a servicing site different from the data center site via the transport infrastructure.

30. The method of claim 15, wherein the transport infrastructure is an intermodal transport infrastructure and wherein each shipping container is configured for transport via the intermodal transport infrastructure.

31. The method of claim 30, wherein each shipping container is configured in accordance with International Organization for Standardization (ISO) container manufacturing standards for transport via the intermodal transport infrastructure.

32. The method of claim 15, in which the building further includes at least one of:

building an interconnecting module to interconnect a plurality of the modular computing modules, the interconnecting module including another of said intermodal shipping container;

building a power generating module for generating power for the at least one modular computing module, the power generating module including another of said intermodal shipping container;

building a power and cooling module integrated with the cooling module for generating power and for providing cooling for the temperature control system, power and cooling module including another of said intermodal shipping container; and

building a cooling tower containing a condenser in fluid communication with the power and cooling module.

33. A data center, comprising:  
a modular computing module, including:

13

- a shipping container configured for transport via a transport infrastructure with respect to at least one of height, length, width, weight, and lifting points of the container;
  - a plurality of computing systems mounted within the shipping container and configured to be shipped and operated within the shipping container;
  - a power distribution unit configured to distribute power from a power source to the plurality of computing systems; and
  - a network interface configured to interface between an Internet access connection and the computing systems;
  - a temperature control system for maintaining a predetermined air temperature surrounding the computing systems; and
  - a cooling module of the temperature control system, the cooling module including another of said shipping container, the cooling module being separate from the computing systems of the modular computing module.
34. The data center of claim 33, in which the modular computing module further includes a plurality of computing system enclosures for enclosing and mounting the computing systems within the enclosures, the computing system enclosures being mounted within the shipping container, and in which the temperature control system includes a temperature control subsystem for each enclosure to provide independent temperature control within the enclosure.
35. The data center of claim 34, in which each computing system enclosure defines a first delivery plenum and a second return plenum in thermal communication with the corresponding temperature control subsystem, the first and second plenums being in thermal communication with the computing system contained within the corresponding enclosure.
36. The data center of claim 35, in which each of the first and second plenums is tapered along its length.

14

37. The data center of claim 34, in which each computing system enclosure includes a gas-side economizer in thermal communication with the corresponding temperature control subsystem.
38. The data center of claim 33, in which the shipping container has a height selected from approximately 8 feet 6 inches and 9 feet 6 inches and a width of approximately 8 feet.
39. The data center of claim 33, wherein the transport infrastructure is an intermodal transport infrastructure and wherein each shipping container is configured for transport via the intermodal transport infrastructure.
40. The data center of claim 39, wherein each shipping container is configured in accordance with International Organization for Standardization (ISO) container manufacturing standards for transport via the intermodal transport infrastructure.
41. The data center of claim 33, further comprising at least one of:
- an interconnecting module to interconnect a plurality of the modular computing modules, the interconnecting module including another of said intermodal shipping container;
  - a power generating module for generating power for the at least one modular computing module, the power generating module including another of said intermodal shipping container;
  - a power and cooling module integrated with the cooling module for generating power and for providing cooling for the temperature control system, power and cooling module including another of said intermodal shipping container; and
  - a cooling tower containing a condenser in fluid communication with the power and cooling module.

\* \* \* \* \*